

**JUMO**

# Регулятор процесса eTRON M100



[www.jumo.nt-rt.ru](http://www.jumo.nt-rt.ru)



**По вопросам продаж и поддержки обращайтесь:**

Архангельск (8182)63-90-72  
Астана +7(7172)727-132  
Белгород (4722)40-23-64  
Брянск (4832)59-03-52  
Владивосток (423)249-28-31  
Волгоград (844)278-03-48  
Вологда (8172)26-41-59  
Воронеж (473)204-51-73  
Екатеринбург (343)384-55-89  
Иваново (4932)77-34-06  
Ижевск (3412)26-03-58  
Казань (843)206-01-48

Калининград (4012)72-03-81  
Калуга (4842)92-23-67  
Кемерово (3842)65-04-62  
Киров (8332)68-02-04  
Краснодар (861)203-40-90  
Красноярск (391)204-63-61  
Курск (4712)77-13-04  
Липецк (4742)52-20-81  
Магнитогорск (3519)55-03-13  
Москва (495)268-04-70  
Мурманск (8152)59-64-93  
Набережные Челны (8552)20-53-41

Нижний Новгород (831)429-08-12  
Новокузнецк (3843)20-46-81  
Новосибирск (383)227-86-73  
Орел (4862)44-53-42  
Оренбург (3532)37-68-04  
Пенза (8412)22-31-16  
Пермь (342)205-81-47  
Ростов-на-Дону (863)308-18-15  
Рязань (4912)46-61-64  
Самара (846)206-03-16  
Санкт-Петербург (812)309-46-40  
Саратов (845)249-38-78

Смоленск (4812)29-41-54  
Сочи (862)225-72-31  
Ставрополь (8652)20-65-13  
Тверь (4822)63-31-35  
Томск (3822)98-41-53  
Тула (4872)74-02-29  
Тюмень (3452)66-21-18  
Ульяновск (8422)24-23-59  
Уфа (347)229-48-12  
Челябинск (351)202-03-61  
Череповец (8202)49-02-64  
Ярославль (4852)69-52-93

# JUMO eTRON M100 Electronic Refrigeration Controller

76mm x 36mm format

## Brief description

The JUMO eTRON M100 is an electronic refrigeration controller for application in cold stores, freezer cabinets or cold displays, for connection to RTD probes Pt100, Pt1000, KTY1X-6 or KTY2X-6. The first measurement input is used to acquire the temperature of the cold store. The second measurement input acquires the evaporator temperature, and ends the defrosting process as soon as the limit for defrosting has been reached. The measurements and parameters are shown in a 3-character backlit display. Three relays are available for the cooling unit, the defrosting heating, and the fan. Alarms can optionally be generated via a relay or by means of the integrated buzzer. The switching states of the relays are indicated via yellow LEDs. Further options include a data logger with an adjustable recording interval for HACCP-compliant documentation<sup>1</sup>, an RS485 interface, and a real-time clock. The electrical connection is made via screw terminals. Four keys serve for instrument operation and parameterization. A setup program and a PC interface are available as accessories, for easy parameterization from the PC, and for evaluating the data logger.

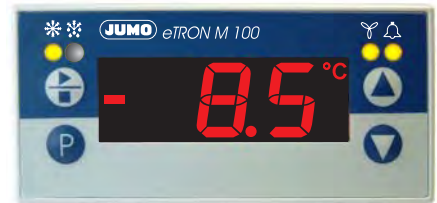

Type 701061/...

## Block diagram

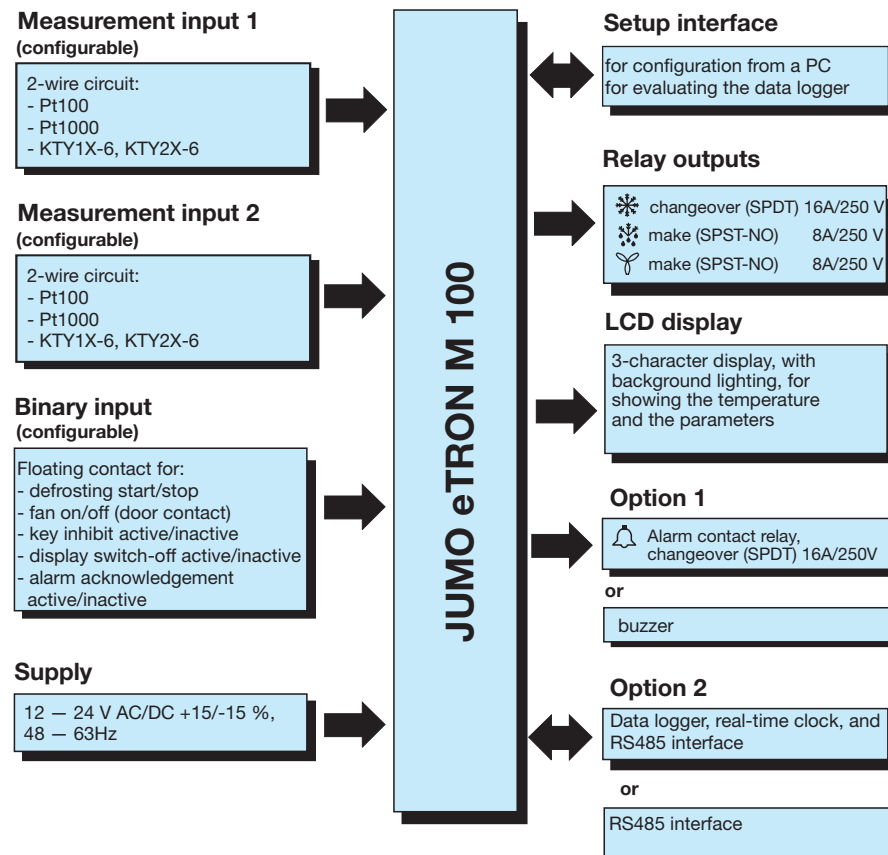







<sup>1</sup> HACCP : Hazard Analysis and Critical Control Point

## Special features

- Choice of “electrical” or “hot gas” defrosting process
- 16A relay for cooling unit and 8A relay for defrosting and fan functions
- 2 analog inputs for RTDs, KTY1X-6 or KTY2X-6 in 2-wire circuit
- Customized linearization is programmable through the setup program
- Operating hours counter with integrated service counter
- Alarm generation via relay or buzzer
- Available with real-time clock, data logger, and RS485 interface
- The data logger records the measurement inputs and switching states of all relays. This makes it possible to implement HACCP monitoring of the cold chain.
- Up to 8 parameters can be enabled individually for the operating level
- The parameter level is protected by a code, thus preventing any unauthorized access to the instrument data.
- Meets the requirements as per EN 12830 and EN 13485
- Setup program for instrument configuration and evaluation of the data logger

## Displays and controls

<b>LCD display</b>	3-character nine-segment display, 13 mm high, and symbols for the temperature unit, hr, min and sec, with red background lighting	 
<b>LED below the symbols</b>	The LEDs <b>Cooling</b> <b>Defrosting</b> <b>Fan and Alarm</b> come on when the corresponding relay is energized.  The LEDs go out when the corresponding relay is de-energized.	
<b>Keys</b>	 for Start/Stop of manual defrosting, acknowledge alarms  Programming  Increase parameter value  Decrease parameter value	
<b>Setup interface</b>	A PC interface and an adapter (4-pole socket) are used to connect the instrument to a PC.	

## Technical data

### Analog inputs

Analog input 1 and 2	Designation	Measuring range	Tolerance in % of measuring range span, temperature effect	Detection of ...	
				probe short-circuit	probe break
<b>RTDs</b>	Pt100 EN 60751	-200 to +600 °C	0.05% (±0.4°C), 100ppm/°C	yes	yes
	Pt1000 EN 60751	-200 to +600 °C	0.05% (±0.4°C), 100ppm/°C	yes	yes
<b>PTC</b>	KTY1X-6	-50 to +100 °C	0.5% (±0.75°C), 100ppm/°C	yes	yes
	KTY2X-6	-50 to +150 °C	0.5% (±1°C), < 100ppm/°C	yes	yes
	resistance 10 — 3500 Ω	customer table <sup>1</sup>	0.075% (±2.6Ω), 100ppm/°C	yes	yes

Measuring current for Pt100: 2 mA, for Pt1000, KTY2X-6, KTY1X-6 and resistor: 0.2 mA

Lead compensation is adjustable via the parameter Lead compensation resistance  $or.1$  and  $or.2$ .

The total resistance at the analog input (probe resistance + selected value for  $or.1$  or  $or.2$ ) must not exceed the following values: 314Ω (with Pt100), 3140Ω (with Pt1000), 2235 Ω (with KTY2x-6), and 3400Ω (with KTY1x-6).

Input resistance	$R_{IN} \geq 100k\Omega$
Sampling time	250msec
Input filter	1st order digital filter; filter constant adjustable from 0.1 to 99.9sec
Measuring current	with Pt100: 0.2mA, with Pt1000, KTY2X-6, KTY1X-6 and resistor: 0.02mA
Lead compensation	adjustable via the parameters Lead compensation resistance $or.1$ and $or.2$
Temperature offset	adjustable via the parameters $ot.1$ and $ot.2$
Special features	temperature indication switchable to °F (Fahrenheit)

<sup>1</sup> A valid customer table must be entered through the setup program and switched over to  $tab$  in the instrument.

### Environmental influences

Ambient temperature range	0 to 55 °C
Storage temperature range	-40 to +70 °C
Climatic conditions	≤ 85 % rel. humidity, no condensation
Shock und vibration	DIN EN 60068-2-6 schedule C.2, Frequency-Range: 10 to 55 Hz Acceleration: 20 m/s <sup>2</sup> (2g)
Care of the front panel	The front panel can be cleaned with normal commercial washing, rinsing and cleaning agents. Do not use any solvents such as methylated spirits, white spirit, P1 or xylol !

### Output

Relay for cooling, changeover (SPDT) Relay for alarm, changeover (SPDT)	70 000 operations at 16A, 250V AC, 50Hz resistive load 60.000 operations at 16A, 250V AC, 50Hz cos phi > 0,6
Relay for defrosting, make (SPST-NO) Relay for fan, make (SPST-NO)	100 000 operations at 8A, 250V AC, 50Hz resistive load 85.000 operations at 8A, 250V AC, 50Hz cos phi > 0,6

**RS485 interface**

Maximum baud rate	38.4 kbaud
Maximum transmission length	< 1200m
Maximum number of stations	32
Priority	The RS485 must not be used while the setup interface is in operation !

**Supply voltage**

Supply voltage	12 – 24V AC/DC +15/-15%, 48 – 63Hz (for operation with SELV circuits only !) (not electrically isolated from the analog inputs)
Power consumption	< 3W

**Housing**

Material	polycarbonate, silver gray RAL 7001
Mounting	in panel cut-out, with bezel seal
Operating position	unrestricted
Weight	approx. 160g
Enclosure protection to EN 60 529, IEC 529	IP65 front, IP20 rear
Flammability class	UL 94 V0

**Electrical data**

Data backup	The data sets of the data logger are saved to a flash memory. The adjustable parameters are stored in EEPROM. Data are preserved after a power interruption.												
Data logger: Recording duration depending from Recording interval (Parameter rEC)	<table border="1"> <thead> <tr> <th>rEC</th> <th>Recording duration</th> </tr> </thead> <tbody> <tr> <td>1 min</td> <td>7 days 19 hours</td> </tr> <tr> <td>5 min</td> <td>39 days (1 month, 9 days)</td> </tr> <tr> <td>15 min</td> <td>117 days (4 month)</td> </tr> <tr> <td>60 min</td> <td>469 days (1year 3 months)</td> </tr> <tr> <td>120 min</td> <td>938 days (2 years 6 months)</td> </tr> </tbody> </table>	rEC	Recording duration	1 min	7 days 19 hours	5 min	39 days (1 month, 9 days)	15 min	117 days (4 month)	60 min	469 days (1year 3 months)	120 min	938 days (2 years 6 months)
rEC	Recording duration												
1 min	7 days 19 hours												
5 min	39 days (1 month, 9 days)												
15 min	117 days (4 month)												
60 min	469 days (1year 3 months)												
120 min	938 days (2 years 6 months)												
Connection circuit	screw terminals for wire cross-sections up to 4 mm <sup>2</sup> , solid wire, up to 2.5 mm <sup>2</sup> , stranded wire												
Electromagnetic compatibility interference emission interference immunity	Product family standard: EN 61326 Class B to industrial requirements												
Operating conditions	The instrument is designed as a panel-mounting unit.												
Electrical safety	EN 60 730, Part 1, overvoltage category III, pollution degree 2												
Accuracy of the real-time clock, buffering	at 25°C: +15/- 15 sec per month, temperature effect: - 0.35 ppm/10°C within the ambient temperature range: +60/- 60 sec per month Gold Cap capacitor buffers the clock time unpowered for about 20 days.												
Technical and functional characteristics of temperature recording devices or thermometers	as per EN 12830 and EN 13485												

**Approval/Marks**

Abbreviation	Inspection authority	valid for
UL	Underwriters Laboratories	only valid for mass-production units with the JUMO symbol

# Connection diagram

Type 701061/XXX-XX

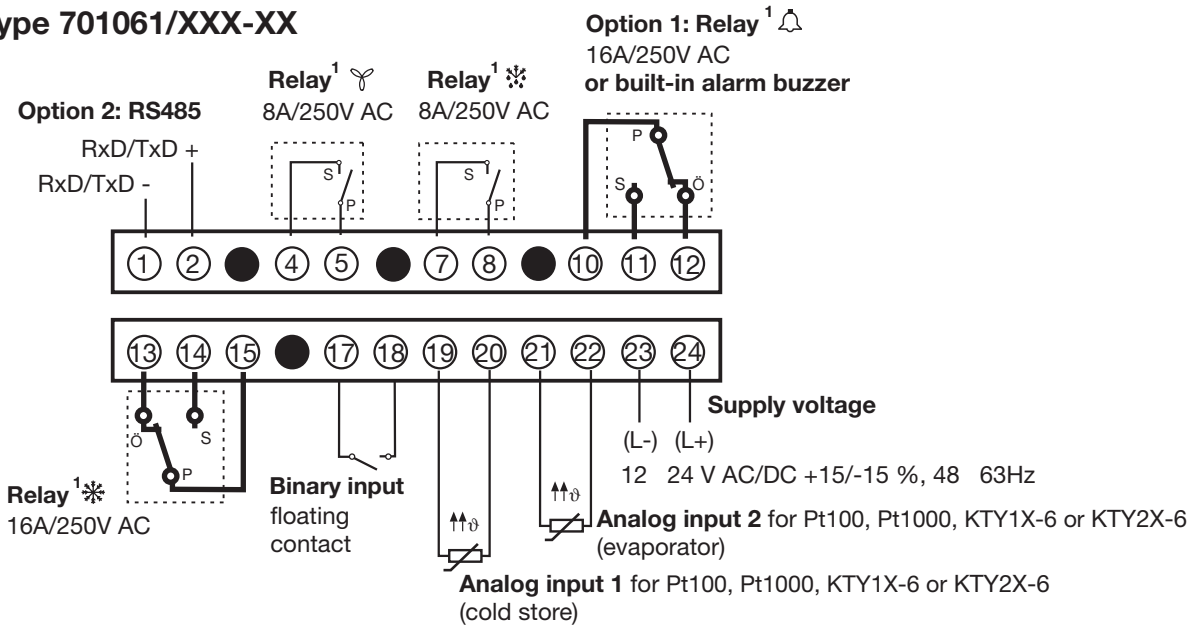

1. The switching positions of the instrument relays shown here (dotted line) represent the relay de-energized condition.

# Dimensions

Type 701061/...

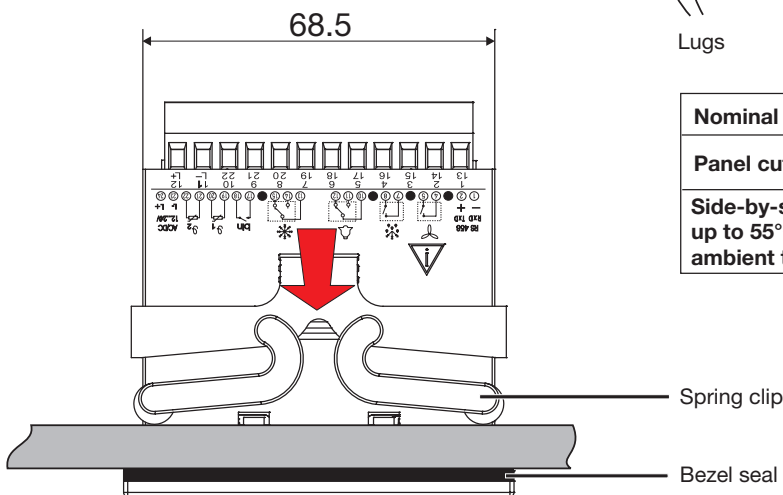
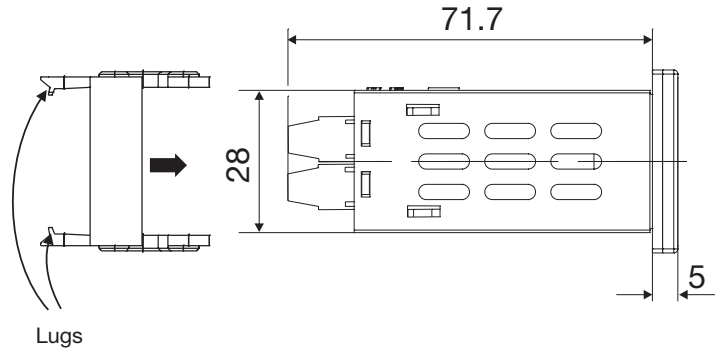
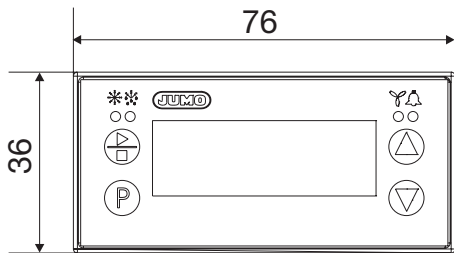

<b>Nominal size</b>	76mm x 36mm
<b>Panel cut-out</b>	69 <sup>+2.5</sup> <sub>-0</sub> mm x 28.5 <sup>+1</sup> <sub>-0</sub> mm
<b>Side-by-side mounting, up to 55°C ambient temperature:</b>	spacing of instruments: 10 mm horizontal 15 mm vertical

# Controller functions

## Cooling, defrosting and fan functions

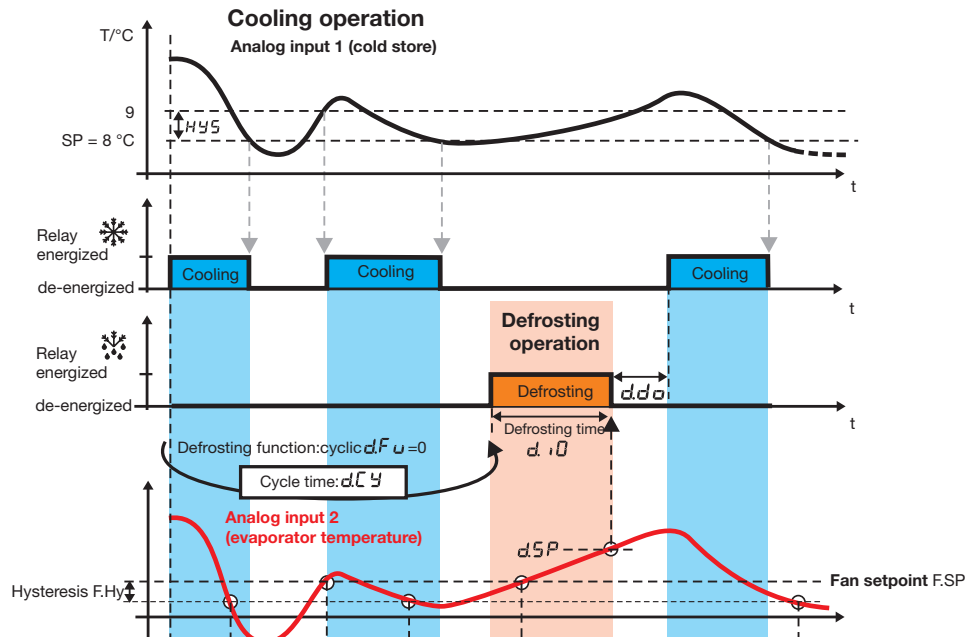

Fan function <i>F.FU</i>	Run-up/ run-down behavior: <i>F.RU</i>	Relay energized/de-energized
0	off	Relay energized/de-energized
0	on	energized/de-energized
1	off	energized/de-energized
1	on	energized/de-energized
2	off	energized/de-energized
2	on	energized/de-energized

*F.dL* is neglected in this operating mode

### Special function: cooling and heating with fan relay

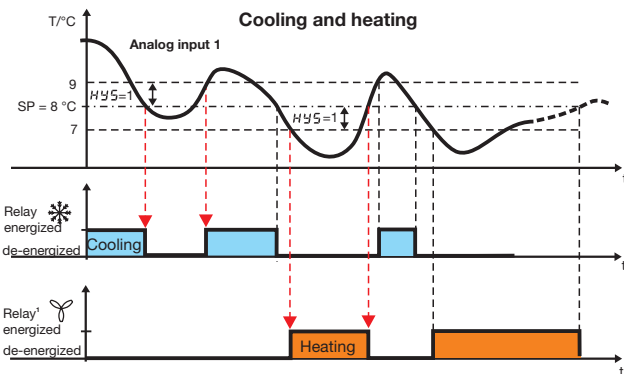

## Order details

		<b>(1) Basic version</b>
	701061	JUMO eTRON M100 with 2 measurement inputs and 3 relay outputs
		<b>(2) Basic type extensions</b>
x	8	factory-set, configurable
x	9	configuration to customer specification
		<b>Option 1</b>
x	0	not available
x	1	buzzer
x	2	alarm contact, changeover (SPDT) contact 16A/250V
		<b>Option 2</b>
x	0	not available
x	1	RS485 interface
x	2	data logger, real-time clock, and RS485 interface
		<b>(3) Supply voltage</b>
x	32	12 – 24V AC/DC +15/-15 %, 48 – 63Hz
		<b>(4) Extra codes</b>
x	000	no Pt100 push-in probe
x	236	2 Pt100 push-in probes (diameter: 6mm, fitting length: 50mm, connecting cable: 1500mm)

	<b>(1)</b>		<b>(2)</b>		<b>(3)</b>		<b>(4)</b>
Order code	<input type="text"/>	/	<input type="text"/>	-	<input type="text"/>	/	<input type="text"/>
Order example	701061	/	8 0 0	-	32	/	000

### 2 Pt100 push-in probes (extra code 236)



### Standard accessories

- 1 Operating Manual
- 1 spring clip and bezel seal

### Accessories - Price Sheet 70.9770

Setup program, multilingual

PC interface with USB/TTL converter, adapter (socket) and adapter (plug)

PC interface TTL / RS232 converter and adapter (socket)

### Accessories - Price Sheet 70.9710

Adapter frame for mounting on DIN rail





The top half of the page features a decorative background of a blue grid pattern. The grid consists of rounded rectangular cells that create a 3D effect, appearing to recede into the distance. The color of the grid transitions from a deep blue on the left to a lighter, almost white blue on the right. In the top right corner, the JUMO logo is displayed in a dark blue, bold, sans-serif font, enclosed within a white rounded rectangle with a dark blue border.

**JUMO**

**По вопросам продаж и поддержки обращайтесь:**

Архангельск (8182)63-90-72  
Астана +7(7172)727-132  
Белгород (4722)40-23-64  
Брянск (4832)59-03-52  
Владивосток (423)249-28-31  
Волгоград (844)278-03-48  
Вологда (8172)26-41-59  
Воронеж (473)204-51-73  
Екатеринбург (343)384-55-89  
Иваново (4932)77-34-06  
Ижевск (3412)26-03-58  
Казань (843)206-01-48

Калининград (4012)72-03-81  
Калуга (4842)92-23-67  
Кемерово (3842)65-04-62  
Киров (8332)68-02-04  
Краснодар (861)203-40-90  
Красноярск (391)204-63-61  
Курск (4712)77-13-04  
Липецк (4742)52-20-81  
Магнитогорск (3519)55-03-13  
Москва (495)268-04-70  
Мурманск (8152)59-64-93  
Набережные Челны (8552)20-53-41

Нижний Новгород (831)429-08-12  
Новокузнецк (3843)20-46-81  
Новосибирск (383)227-86-73  
Орел (4862)44-53-42  
Оренбург (3532)37-68-04  
Пенза (8412)22-31-16  
Пермь (342)205-81-47  
Ростов-на-Дону (863)308-18-15  
Рязань (4912)46-61-64  
Самара (846)206-03-16  
Санкт-Петербург (812)309-46-40  
Саратов (845)249-38-78

Смоленск (4812)29-41-54  
Сочи (862)225-72-31  
Ставрополь (8652)20-65-13  
Тверь (4822)63-31-35  
Томск (3822)98-41-53  
Тула (4872)74-02-29  
Тюмень (3452)66-21-18  
Ульяновск (8422)24-23-59  
Уфа (347)229-48-12  
Челябинск (351)202-03-61  
Череповец (8202)49-02-64  
Ярославль (4852)69-52-93

сайт: <http://jumo.nt-rt.ru> || эл. почта: [jmu@nt-rt.ru](mailto:jmu@nt-rt.ru)